



R-5320B/FLR



R-5320B/CRS

DATI TECNICI

- **Codice:** R-5320B
- **Descrizione:** ricarica deodorante per air freshener IN-5320B
- **Durata fragranza:** 60 giorni
- **Peso netto:** 0,064 Kg

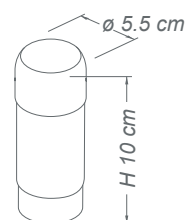

GAMMA DI PRODUZIONE E VENDITA

GAMMA STANDARD

R-5320B/FLR	fragranza FLAIR (bassa intensità)
R-5320B/CRS	fragranza CRUSH (alta intensità)

IMBALLI/CONFEZIONI

IMBALLO

N° 6 ARTICOLI

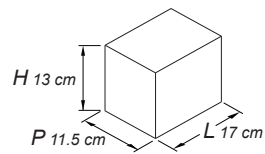

PESO LORDO 0.46 Kg
PESO NETTO 0.384 Kg

IMBALLO MULTIPLIO

N° 40 SCATOLE DA 6 RICARICHE cad.
TOTALE 240 ARTICOLI

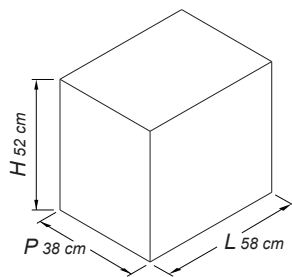

PESO LORDO 19.7 Kg
PESO NETTO 15.3 Kg

PALLET IMBALLO MULTIPLIO

8 SCATOLE MULTIPLE PER PALLET
TOTALE 1920 ARTICOLI PER PALLET

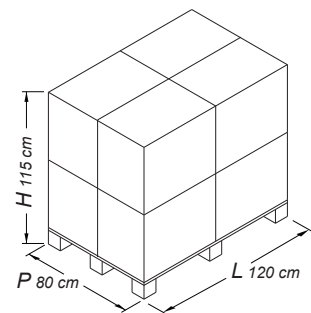

PESO LORDO 170 Kg
PESO NETTO 122 Kg